



Sovereign Place
Town Centre

RETAIL STAGE 1 LEASING OPPORTUNITY

Prepared by Mr Michael Long
Head of Development, Lewis Land Group

the place to be

PLANNED FOR GROWTH

The \$500million Sovereign Place Town Centre will be one of the largest Retail, Health and Business Centres in the region, providing unrivalled convenience, nestled amongst a lively town green, lake and community library.

Sovereign Place
Retail Stage One

PROPOSED MASTER PLAN

A growing Town Centre of mixed use
Retail, Health and Business Precincts.

- Approx. 60,000+sqm GLA
- Unique high-end architecture, open-air and nature focused design, applying sustainable design principles
- Up to 100 businesses with 1,000 employees onsite
- Emphasis on employee wellbeing and connection
- Approx. 1,000 carpark, including EV charging stations
- NBN ready and high-speed data

Stages include:

- 1 Retail – Stage One (Now Open)
- 2 Mixed Use Retail – Stage Two
- 3 Future Large Format Retail
- 4 Business & Technology Park
- 5 Health & Wellbeing Precinct
- 6 Commercial Offices
- 7 Entertainment & Leisure Precinct

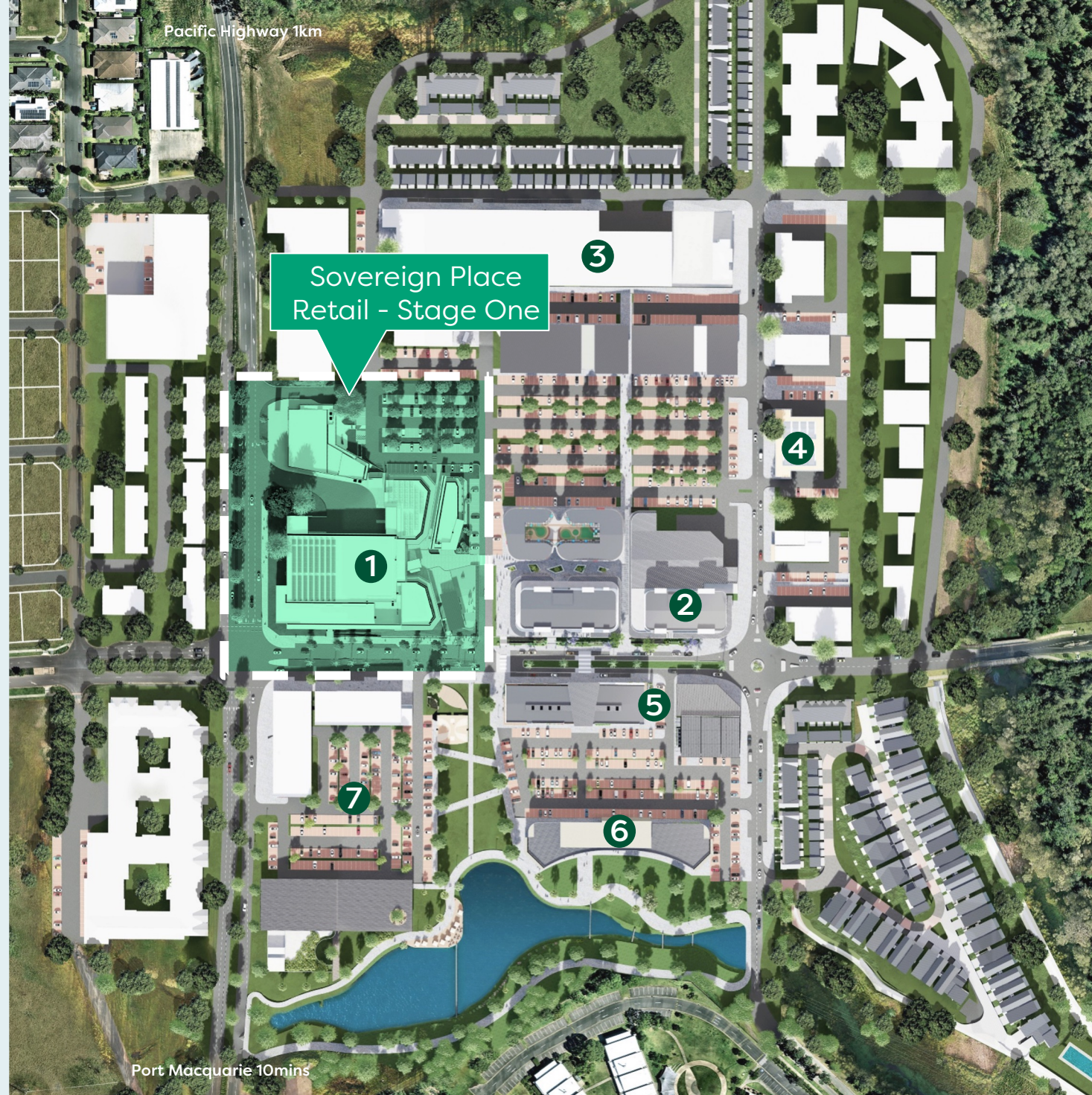

THE PLACE FOR YOUR BUSINESS

Sovereign Place Town Centre is a best-in-class destination connecting local, regional and national businesses with customers, a thriving community and each other.

- Strategically located in Port Macquarie – the major growth corridor of New South Wales' Mid North Coast
- Convenient location at junction of Pacific and Oxley Highways draws visitation from significant geographic area
- One of the only greenfield town centres approved in the Hastings region for the next 10 years
- Part of the \$1 billion+ Sovereign Hills master planned community
- At 60,000+sqm, it's the largest retail, health and business centre in the region
- Stage One of Sovereign Place opened in 2019, comprising 6,100sqm GLA of retail and commercial space for approx. 21 tenants
- Partner with Lewis Land Group, with 60 years' experience in developing retail centres, including Harbour Town Gold Coast and Adelaide, and master planned communities across Australia



THE PLACE FOR CONVENIENCE

Connecting communities to convenience has never been more important than in today's fast paced world. Whether it's a quick gym workout before work, catching up with friends for a leisurely lunch, or grabbing groceries for dinner before the school pick-up, at Sovereign Place Town Centre shopping has never been easier

Stage One features:

- Located in a highly visible area within an established and popular shopping precinct
- Enroute to St Joseph's Regional College and future regional playing fields, near childcare centre and proposed aged care facility
- Inclusive and engaging open-air design with IGA Supermarket + Liquor, cafés, chemist and health, hair and beauty, fitness, vet hospital and specialties
- Flat, easy direct access to shops, with ample parking & EV charging stations
- Close proximity to homes with easy walkability



THE PLACE TO SHOP.EAT.WORK.

Sovereign Place is the place for groceries, yummy treats, health, beauty and more... there's always something new to discover. Our town centre will grow in stages over the next decade as will the opportunities to work where you live.

LEASING OPPORTUNITY...

We're currently inviting leasing enquiries for the remaining tenancy in Stage One

55sqm tenancy is now available for:

- Optometrist
- Allied health services
- Financial services
- General retail
- Bakery
- Bicycle retail/repairs



OUR FAMILY OF RETAILERS

- 1 IGA + Liquor
- 3 Soul of Seoul (Korean cuisine)
- 5 The Beauty Collective
- 6 Triple Two (Homewares)
- 7 AVAILABLE - 55m2
- K Peakface Lifestyle Café (Kiosk)
- 9 Pro Mobile Repair
- 10 Brooklyn's Burger. Bar. Espresso
- 11 Your Discount Chemist
- 12 **New business coming soon**
- 14 Salon Salty
- 15 Noona's Pizzeria
- 16 The Hill Café
- 21 Mid North Coast Allied Health
- 22 **New business coming soon**
- 23 Leslie Williams MP Electorate Office
- 25 Southern Cross Austereo (L1)
- 26 Hastings Co-Op (L1)
- 30 Sovereign Vet Hospital
- 31 Painted Horse Tattoo
- A Painted Horse Barbers
- 32 Your life Fitness Centre



TENANCY 7 NOW LEASING

Offering you full leasing flexibility with long-term lease options and the opportunity for you to create a custom-designed fitout.

Let's start the conversation...

Tell us about your business and our experienced team will:

- share the leasing terms and details with you
- work with you throughout the fitout process to develop a retail space that is perfectly suited to meet your requirements.

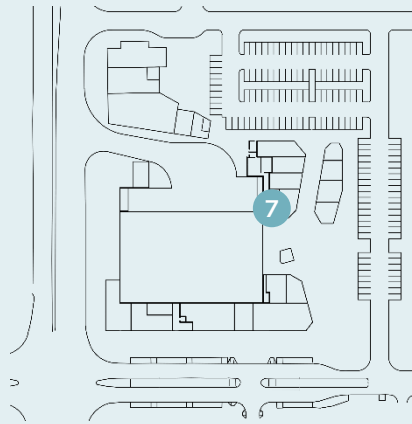

DON'T
MISS OUT

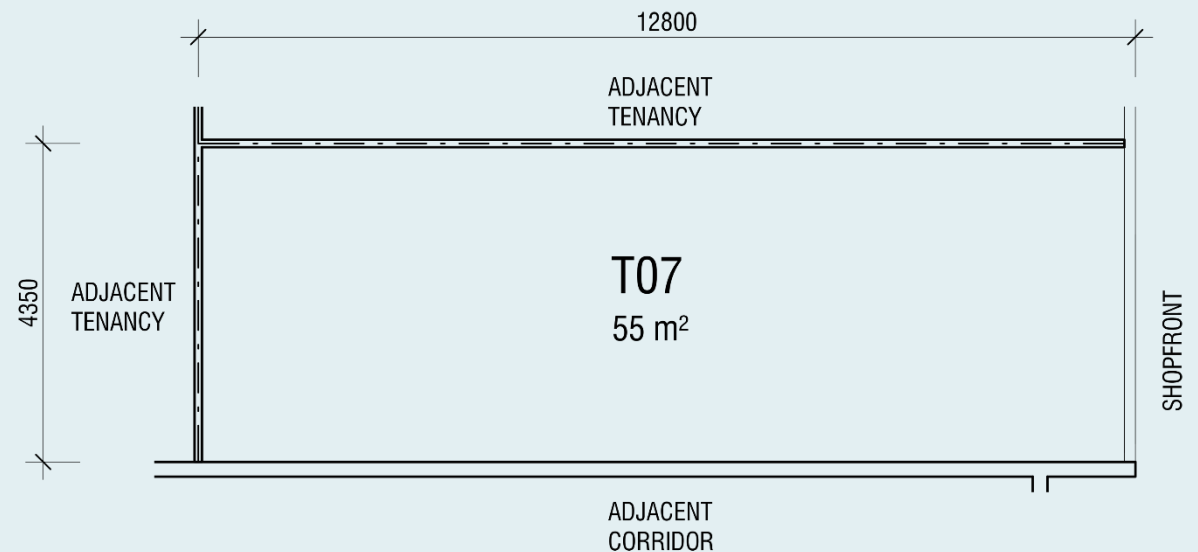

The logo for Sovereign Place Town Centre features a stylized green leaf icon to the left of the text. The text 'Sovereign Place' is in white, and 'Town Centre' is in a teal color.

Sovereign Place Town Centre

We'd love for you to join us.

For enquiries, please contact:

Sean Kelly
Centre Manager
Lewis Land Group

0478 047 121
sean.kelly@sovereignhills.com

Disclaimer: This publication provides information about one of the shopping centres owned or managed by Lewis Land Group Pty Ltd. Whilst all reasonable efforts have been made to ensure the information is accurate and up to date, Lewis Land Group Pty Ltd maintains the right to update or change the information at any time without notice to users. No responsibility is taken by Lewis Land Group Pty Ltd for any decisions made based on this information. Version 1 April 24

lewisland.com

L
LEWIS
LAND
GROUP