

ESTIMATED GROSS LETTABLE AREA

Warehouse (inc. WH offices/amens.)	2,703.1 sq. metres
Mezzanines	207.3 sq. metres
Showroom/Offices/Amenities	1,303.0 sq. metres
Shed	167.3 sq. metres
<hr/>	
Total Improvements	4,380.7 sq. metres
Site (approx.)	1.430 Ha
	14,300 sq. metres

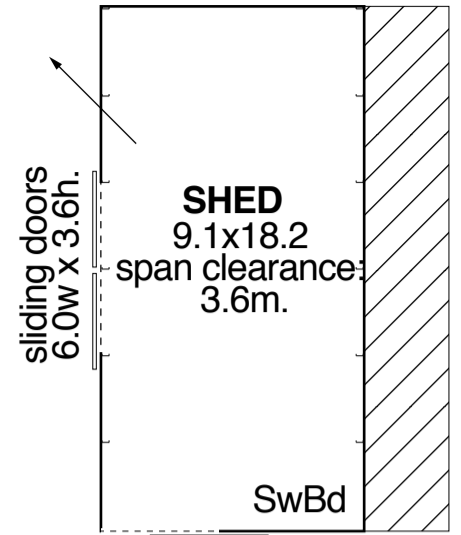

Complies with the PCA Method of Measurement

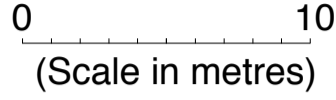