

ALL FIXTURES, FITTINGS, GRAB RAILS, SYMBOLS, TACTILE INDICATORS & SIGNAGE TO DISABLED FACILITIES SHALL COMPLY WITH AUSTR. STANDARD AS 1428.1

UNISEX DISABLED

SCALE: 1:20

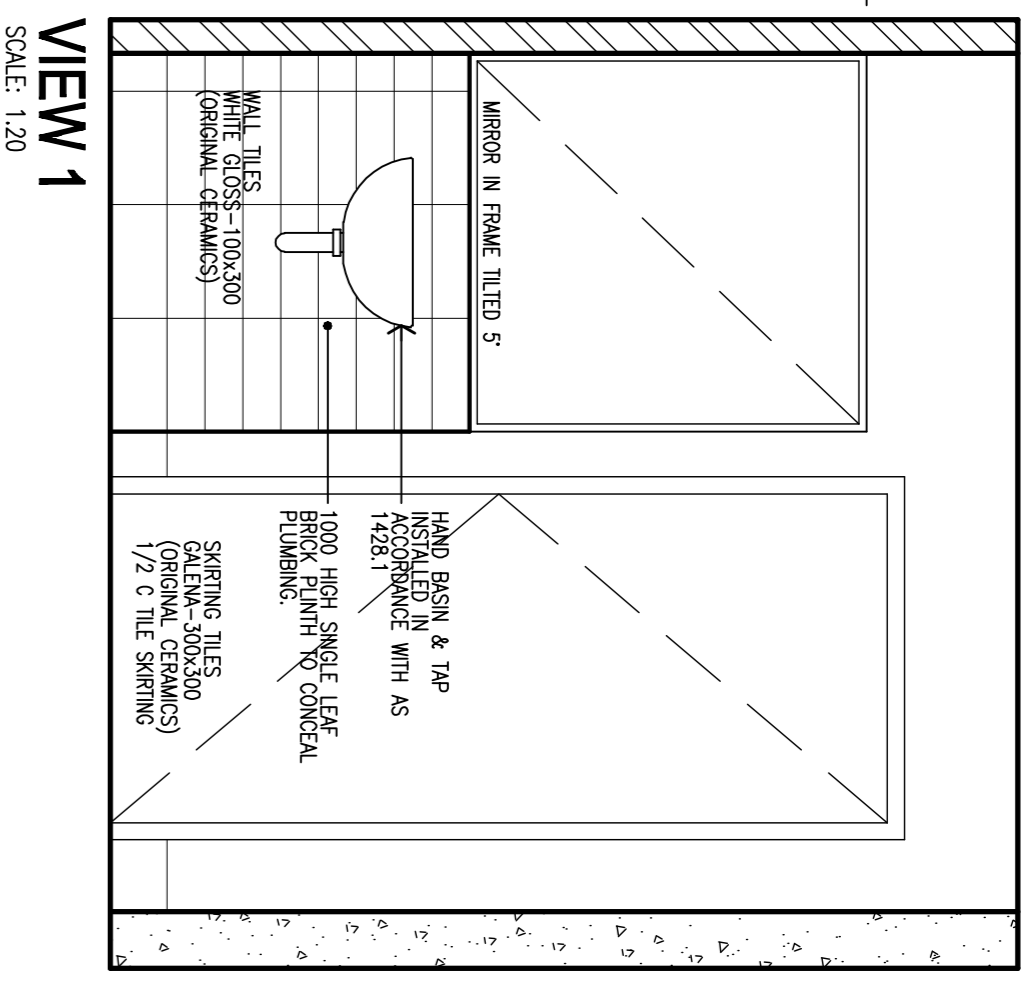

VIEW 1

SCALE: 1:20

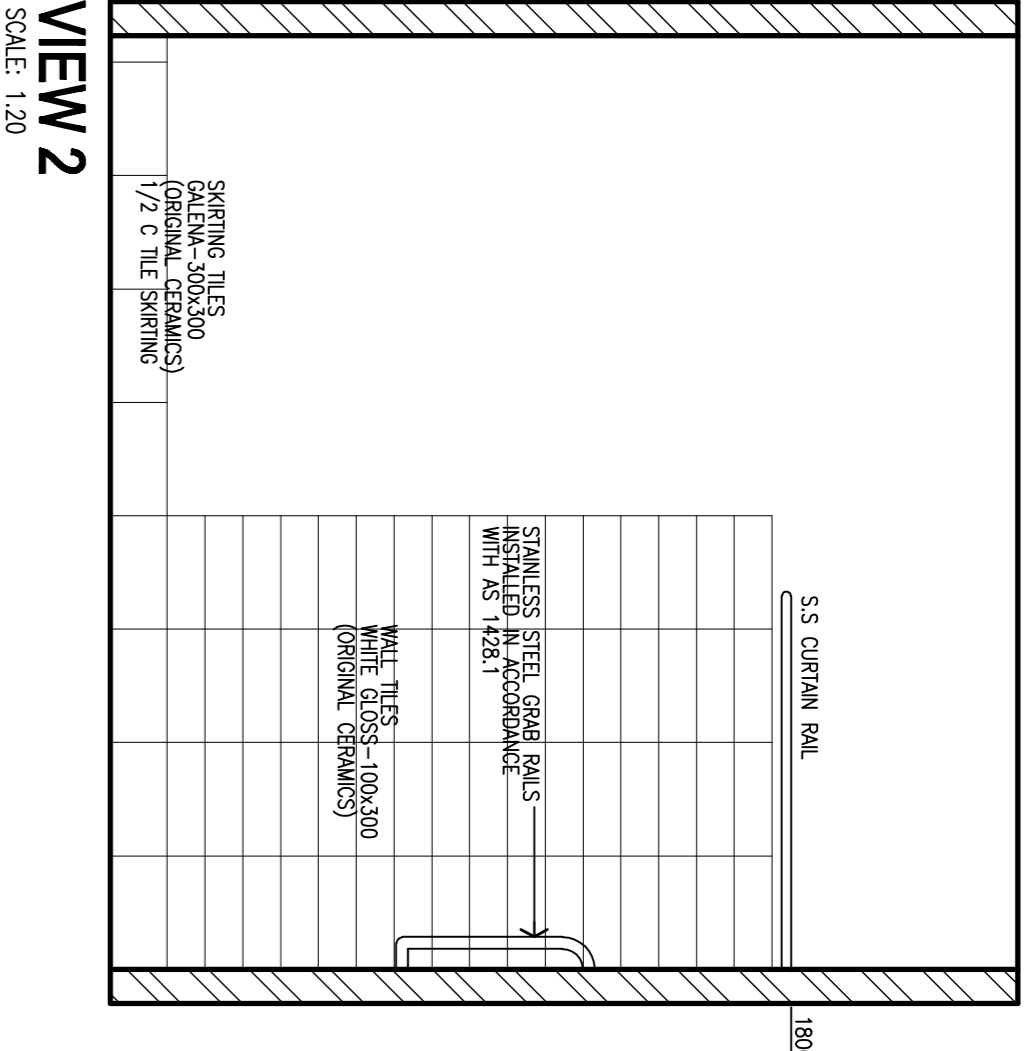

VIEW 2

SCALE: 1:20

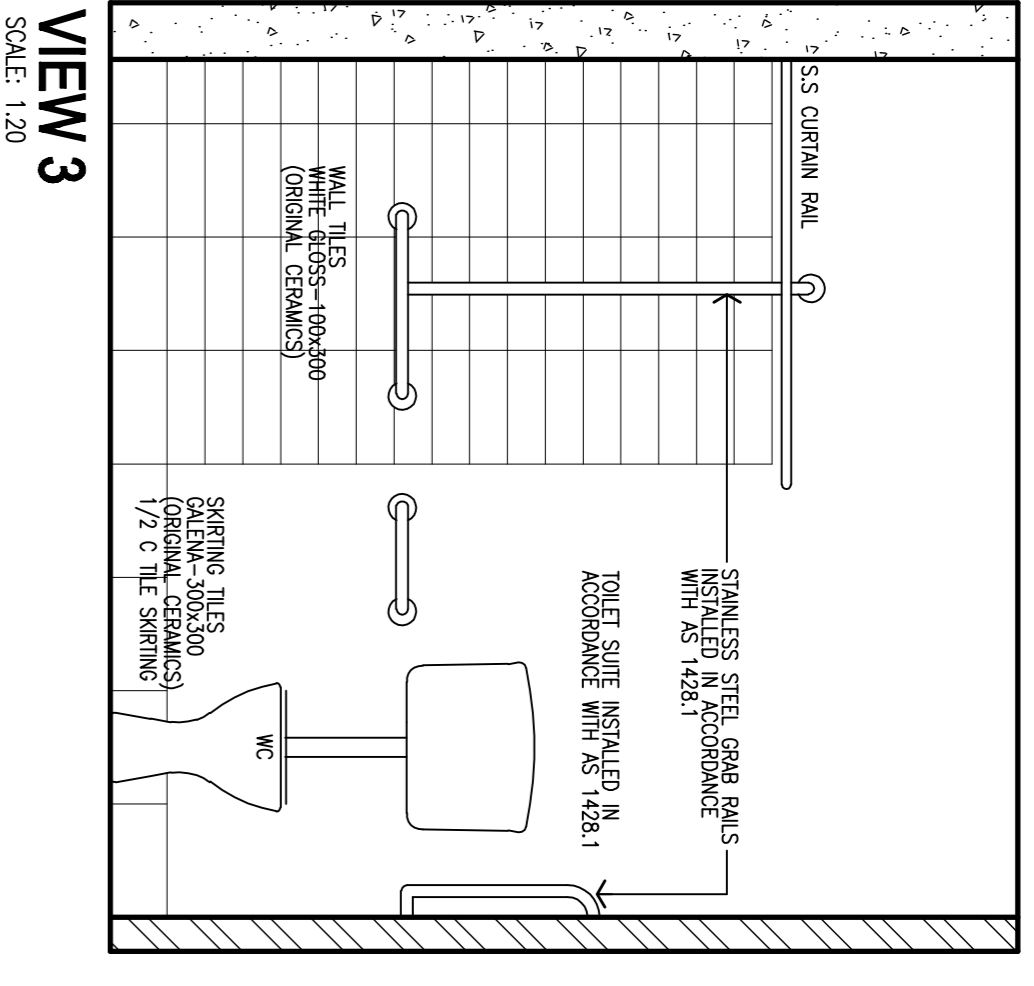

VIEW 3

SCALE: 1:20

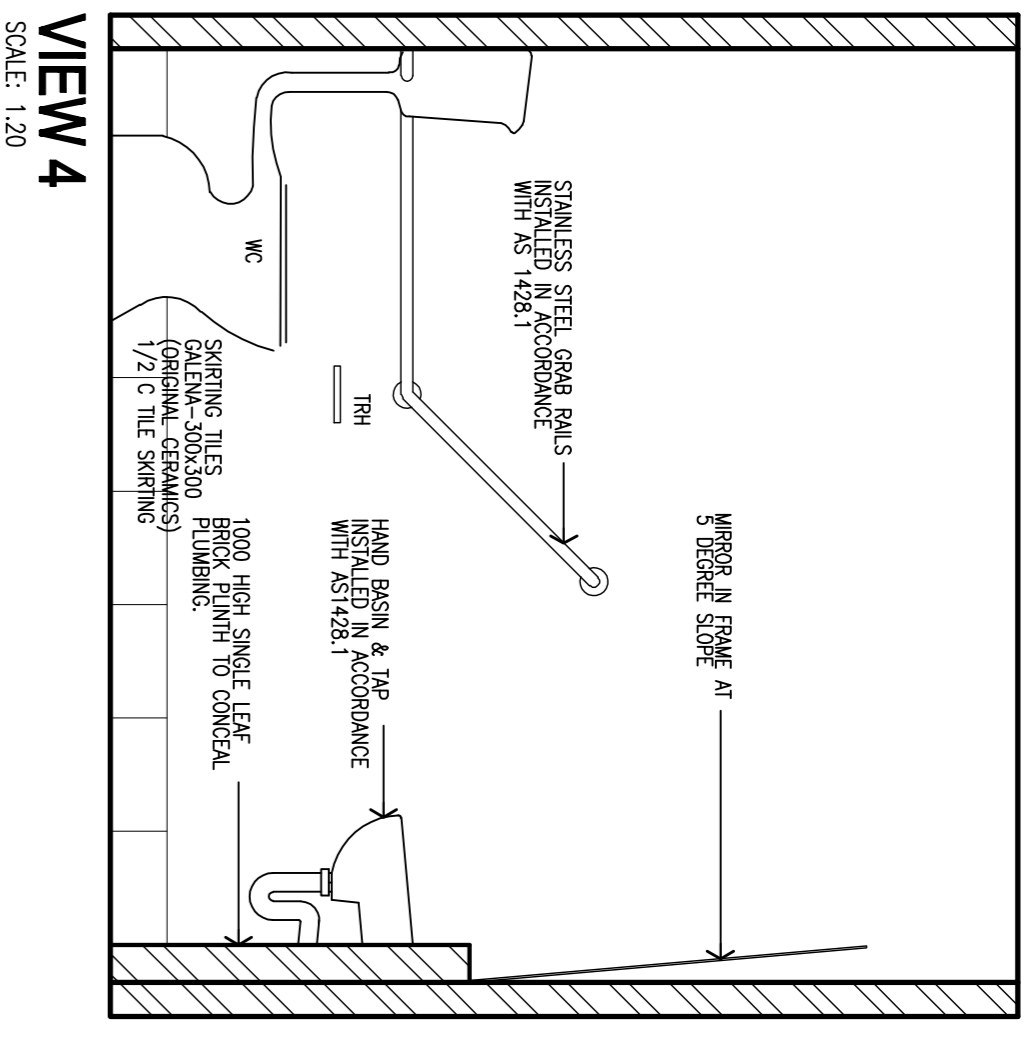

VIEW 4

SCALE: 1:20

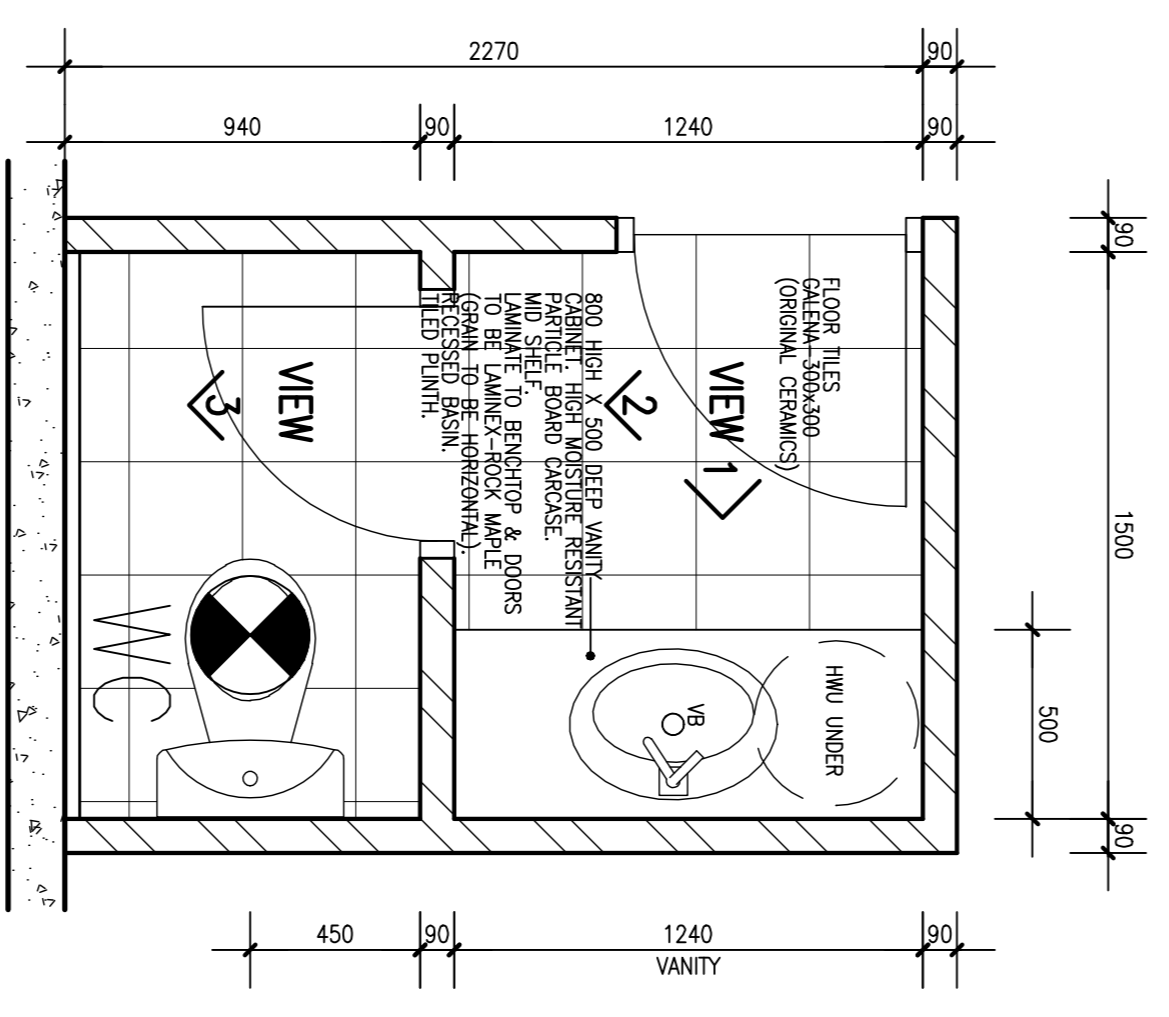

MALE WC

SCALE: 1:20

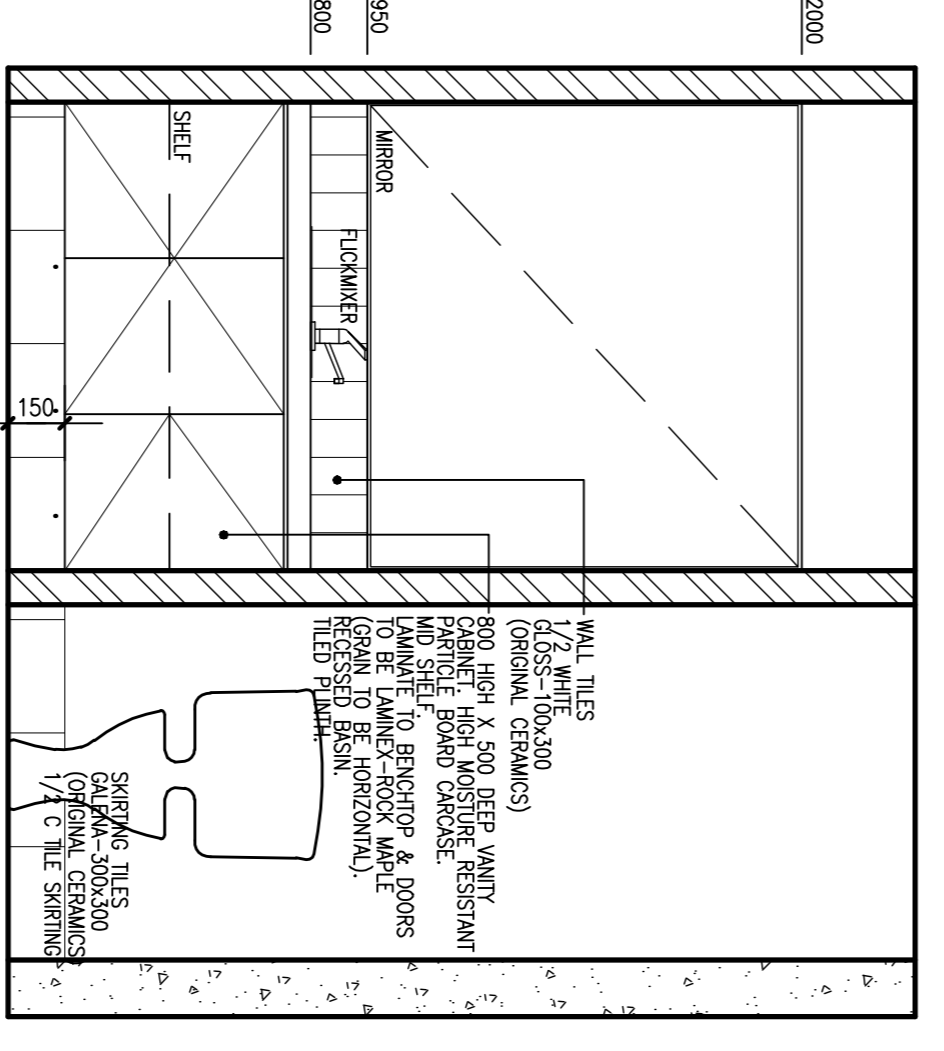

VIEW 1

SCALE: 1:20

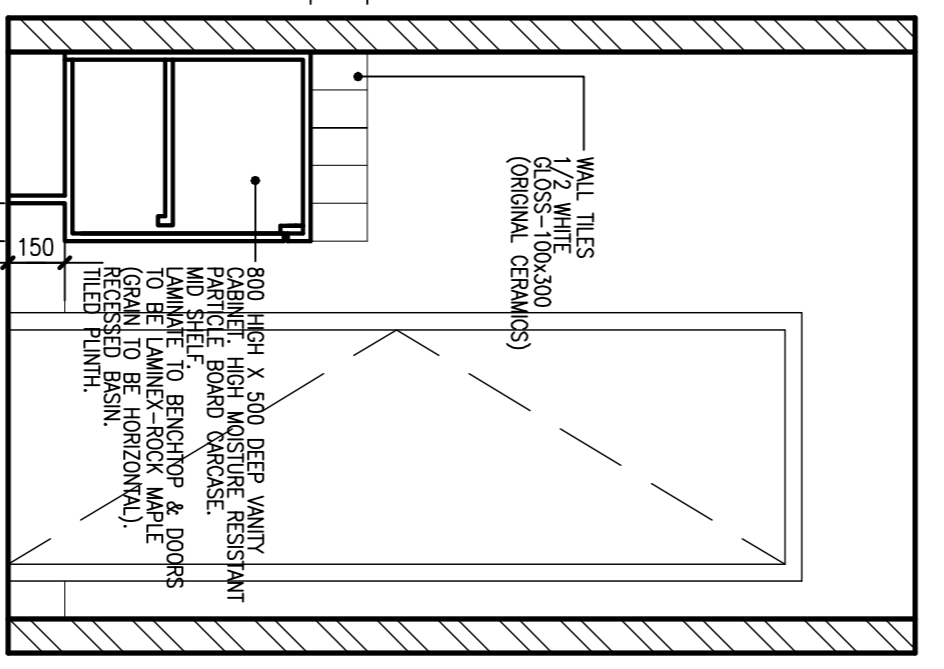

VIEW 2

SCALE: 1:20

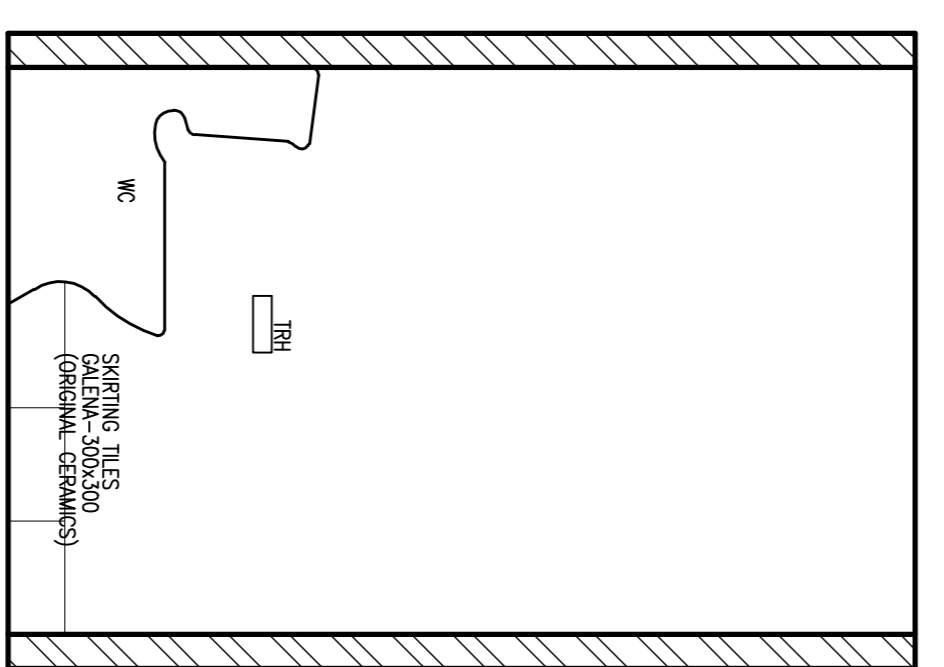

VIEW 3

SCALE: 1:20

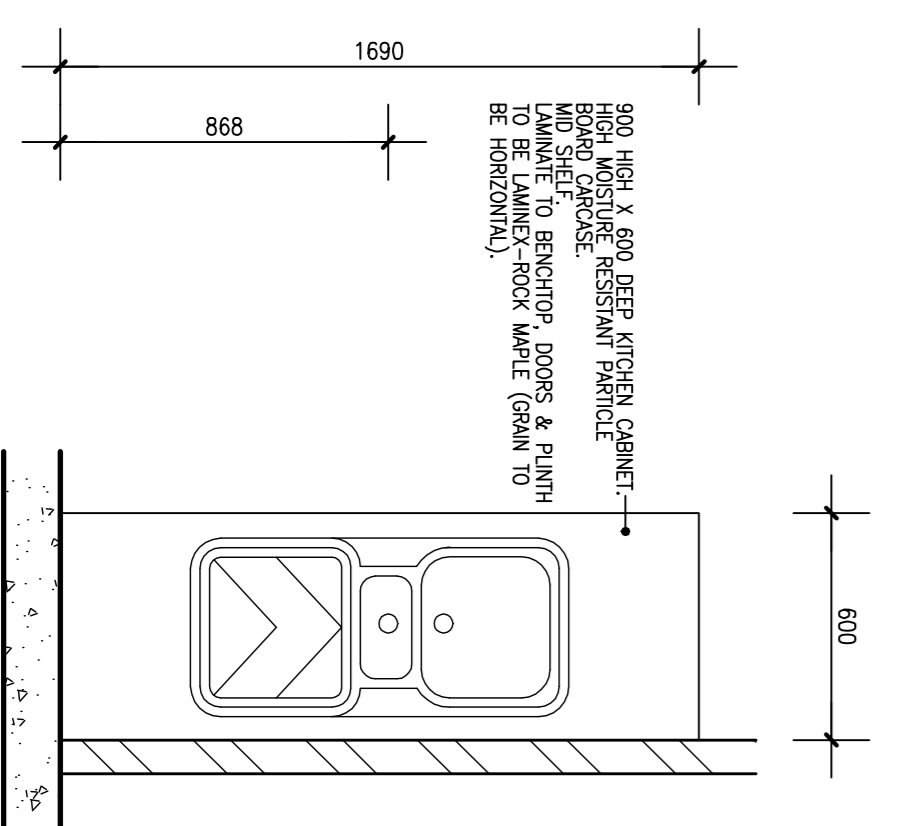

TEA PREP

SCALE: 1:20

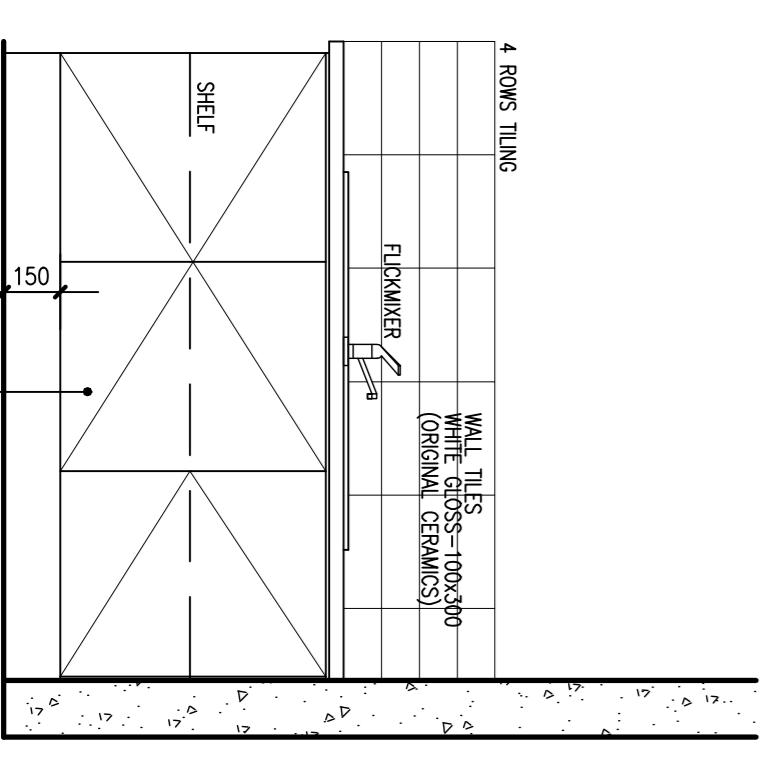

VIEW 1

SCALE: 1:20

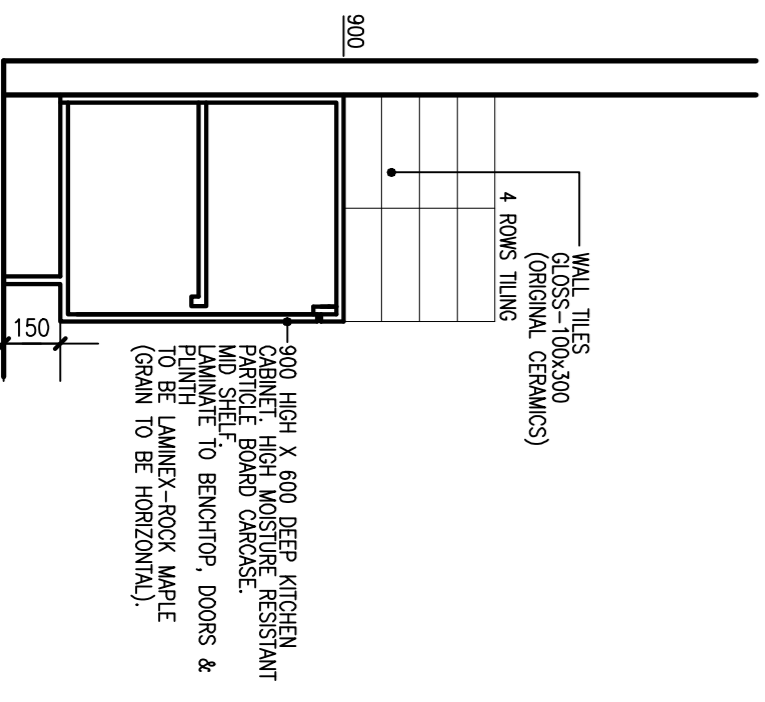

VIEW 2

SCALE: 1:20

WAREHOUSE 1 ROOM LAYOUTS ONLY.
WAREHOUSE 2 ROOM LAYOUTS ARE A
MIRRORED COPY.

C	CONSTRUCTION ISSUE	6.04.08
B	CONTRACT ISSUE	30.04.06
A	BUILDING LICENSE	13.03.08

PROPOSED OFFICES & WAREHOUSES
for SIKA PROPERTIES PTY LTD
at LOT 1013 MALLANG WAY
CANNING VALE

ROOM LAYOUTS

COMMERCIAL designMANAGEMENT

2 Permenter st Mth Fremantle 6159
BUILDER TO VERIFY DIMENSIONS AND SET OUT AND REFER DISCREPANCIES TO DESIGNER FOR DIRECTION
DRAWN BC CHECKED TO DATE
SCALE 1:20 DATE FEB 2008 DWG No. A12 OF A12